



Product Catalog

HFCF PEAK

Horizontal Concealed Chilled Water Fan Coil Unit

Airflow: 200~1500 CFM

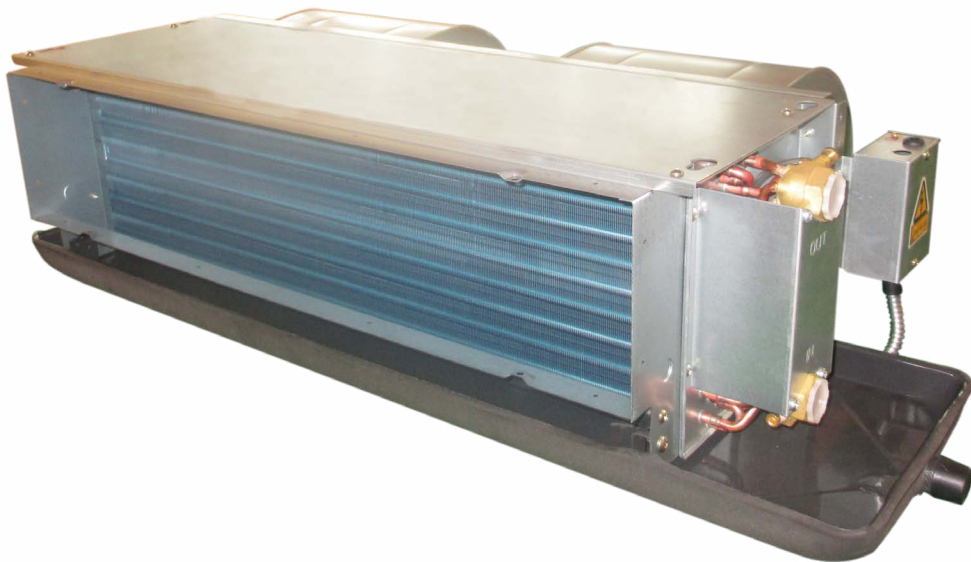

Features and Benefits

Overview

HFCF is another leap over the leading HFCF, working everywhere around the world. HFCF meets the standards of today's market, as well as the anticipated needs of tomorrow's market. The tradition that company founder Reuben Trane began in the 1930s continues with the latest generation of fan-coils from The Trane Company.

The best design we are offering by HFCF:

- Louver fin to drive higher heat transfer efficiency
- Larger diameter fan to further improve noise level
- Various ESP (External Static Pressure) motor options to provide more precise match
- Dedicated EarthWise™ (large delta T application) coil option
- Full AQP in design and production process to ensure quality delivery
- Many newly patented designs to deliver unique comfort

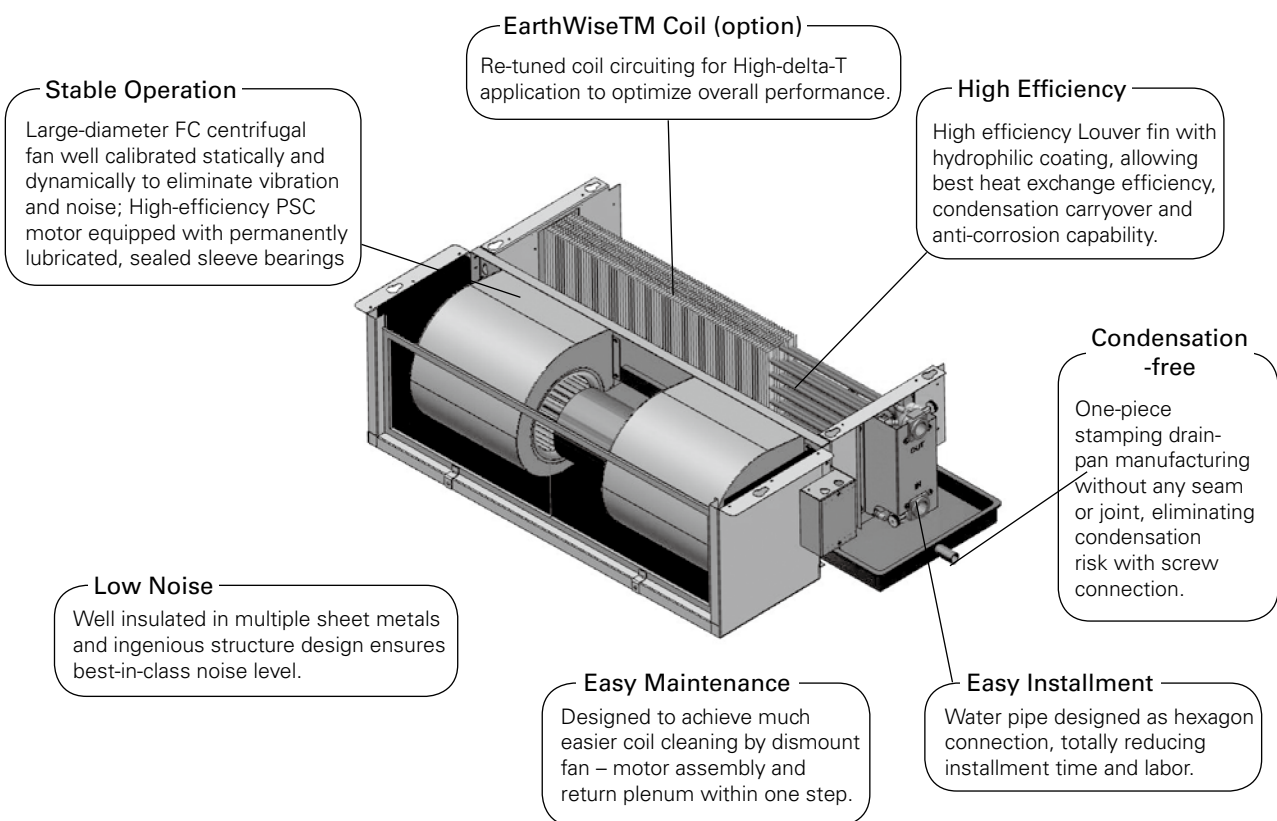

Note: HFCF11, 13, 15 with PSC Motor-ESP 100Pa options are not AHRI certified.

Model Number Descriptions

H F C F 0 2 L 3 0 1 1 0 0 0 A 0 2 A
 1 2 3 4 5 6 7 8 9 10 11 12 13 14 15 16 17 18

Digits 1-4	Unit Type H Horizontal F Fan Coil Unit C Concealed F Platform Version	Digit 11	Voltage/Hertz/Phase 1 220 ~ 240VAC/50Hz/1Phase 2 220 ~ 240VAC/60Hz/1Phase 3 110 ~ 127VAC/60Hz/1Phase
Digits 5-6	Size--Nominal CFM 02 200 CFM 03 300 CFM 04 400 CFM 05 500 CFM 06 600 CFM 08 800 CFM 10 1000 CFM 11 1100 CFM 12 1200 CFM 13 1300 CFM 14 1400 CFM 15 1500 CFM	Digit 12	Valve 0 None A 2-way Valve (2-pipe) B 3-way Valve (2-pipe) C Two 2-way Valves (4-pipe)
Digit 7	Connection Side L Left Hand Connection R Right Hand Connection	Digit 13	Control 0 No Control A LCD Thermostat (TM50)
Digit 8	Coil Rows 2 2 rows 3 3 rows 4 4 rows A 2+1 rows B 3+1 rows C 3 rows (EarthWise) D 4 rows (EarthWise) E 3+1 rows (EarthWise) H 3 rows hi-capacity (EarthWise) 6 2 rows, [2.5MPa] 7 3 rows, [2.5MPa] 8 4 rows, [2.5MPa] P 2+1 rows, [2.5MPa] Q 3+1 rows, [2.5MPa] R 3 rows (EarthWise), [2.5MPa] S 4 rows (EarthWise), [2.5MPa] T 3+1 rows (EarthWise), [2.5MPa] W 3 rows hi-capacity (EarthWise), [2.5MPa]	Digit 14	Plenum Filter 0 None A Rear Return Air Plenum B Rear Return Air Plenum w/ 6mm Nylon Filter C Rear Return Air Plenum w/ 20mm AI Filter D Bottom Return Air Plenum E Bottom Return Air Plenum w/ 6mm Nylon Filter F Bottom Return Air Plenum w/ 20mm AI Filter
Digit 9	Electric Heater 0 No Electric Heater 1 With Electric Heater (w/ Relay in Terminal Box) 2 With Electric Heater (w/o Relay in Terminal Box)	Digit 15	Drain Pan A Cold-roll Steel, PE Insulation B Cold-roll Steel, PE Insulation (+200mm) C Cold-roll Steel, PE Insulation (+310mm) D Stainless Steel, PE Insulation E Stainless Steel, PE Insulation (+200mm) F Stainless Steel, PE Insulation (+310mm) G Cold-roll Steel, Non-flammable Insulation H Cold-roll Steel, Non-flammable Insulation (+200mm) J Cold-roll Steel w/ Non-flammable Insulation (+310mm) K Stainless Steel w/ Non-flammable Insulation L Stainless Steel w/ Non-flammable Insulation (+200mm) M Stainless Steel w/ Non-flammable Insulation (+310mm) N Cold-roll Steel, PE Insulation + aux drain pan P Cold-roll Steel, PE Insulation (+200mm) + aux drain pan Q Cold-roll Steel, PE Insulation (+310mm) + aux drain pan R Stainless Steel, PE Insulation + aux drain pan S Stainless Steel, PE Insulation (+200mm) + aux drain pan T Stainless Steel, PE Insulation (+310mm) + aux drain pan U Cold-roll Steel, Non-flammable Insulation + aux drain pan V Cold-roll Steel, Non-flammable Insulation (+200mm) + aux drain pan W Cold-roll Steel w/ Non-flammable Insulation (+310mm) + aux drain pan X Stainless Steel w/ Non-flammable Insulation + aux drain pan Y Stainless Steel w/ Non-flammable Insulation (+200mm) + aux drain pan Z Stainless Steel w/ Non-flammable Insulation (+310mm) + aux drain pan
Digit 10	Motor Type 1 PSC Motor-ESP 12Pa 3 PSC Motor-ESP 30Pa 5 PSC Motor-ESP 50Pa A PSC Motor-ESP 100Pa	Digit 16	IAQ Option 0 No IAQ Option
		Digit 17	Design Version 2 Design Version
		Digit 18	Region A APR B MAIR C LAR H HongKong V China

Performance Data

3 Row Unit (2-Pipe, 12/30/50Pa Motor)

			02	03	04	05	06	08	10	12	14	
Air Flow	High Speed	CMH	340	510	680	850	1020	1360	1700	2040	2380	
	Middle Speed	CMH	280	410	550	690	830	1100	1360	1630	1900	
	Low Speed	CMH	180	270	350	440	520	690	860	1020	1190	
Normal Application ⁽²⁾	Cooling Capacity	kW	2.21	3.16	4.17	5.06	6.10	8.00	9.30	11.10	13.00	
	Heating Capacity	kW	3.50	5.20	6.70	8.12	9.70	13.00	15.50	18.00	20.80	
	Heating Capacity (by E-heater) ⁽⁶⁾	kW	0.50	1.00	1.40	1.60	1.80	2.80	3.20	3.60	4.60	
	Water Flow	l/s	0.11	0.15	0.20	0.25	0.30	0.39	0.45	0.53	0.63	
	Water Pressure Drop	kPa	25	24	25	30	40	35	35	40	50	
EarthWise Application ⁽³⁾	Cooling Capacity	kW	2.21	3.14	3.99	5.02	6.10	7.98	9.85	11.31	13.29	
	Heating Capacity	kW	3.37	4.84	6.32	7.56	9.16	12.27	14.92	17.15	19.95	
	Water Flow	l/s	0.07	0.10	0.12	0.16	0.20	0.24	0.29	0.34	0.40	
	Water Pressure Drop	kPa	29	22	17	29	40	33	36	35	50	
High Capacity EarthWise Application	Cooling Capacity	kW	-	2.06	2.70	3.39	4.20	5.41	6.53	7.49	8.87	
	Heating Capacity	kW	-	3.61	4.73	5.93	7.35	9.47	11.43	13.11	15.52	
	Water Flow	l/s	-	0.06	0.08	0.11	0.12	0.16	0.19	0.22	0.27	
	Water Pressure Drop	kPa	-	28	20	30	22	40	35	35	48	
Power Consumption	12Pa	220 ~ 240V/50Hz	W	26	39	45	68	96	130	152	189	228
		220 ~ 240V/60Hz	W	27	43	51	67	85	118	142	178	213
		100 ~ 127V/60Hz	W	28	40	52	68	79	120	145	179	201
		220 ~ 240V/50Hz	W	41	55	71	87	108	150	174	212	253
	30Pa	220 ~ 240V/60Hz	W	36	49	62	87	88	126	163	193	311
		100 ~ 127V/60Hz	W	33	47	59	81	86	131	166	191	336
		220 ~ 240V/50Hz	W	48	64	84	99	118	164	210	230	290
	50Pa	220 ~ 240V/60Hz	W	40	58	77	112	134	189	242	273	333
		100 ~ 127V/60Hz	W	40	62	75	110	147	195	239	277	374
		12Pa	W	34.5	35.5	36.5	40.5	45.0	44	46.5	49.0	51.0
Noise	30Pa	dBA	38.0	40.0	41.5	43.5	46.0	46.5	49.0	51.0	53.0	
	50Pa	dBA	41.0	42.5	45.0	47.0	48.0	49.0	51.0	52.0	54.0	
	Number of Motors		1	1	1	1	1	1	2	2	2	
Working Pressure		1.8MPa										
Coil Type		Copper Tube / Hydrophilic Aluminum Fin										
Fan Type		Forward-Curve Centrifugal Fan										
Motor Type		Single-phase Permanent Split Capacitor										
Water Inlet/Outlet Diameter		Rc 3/4" (Female)										
Drain-pan Type		One-piece Stamping & Electrostatic Coating										
Drain-pan Connection Diameter		R 3/4" (Male)										
Options		Return Air Plenum, Filter, Thermostat, E-heater, Special Drain-pan										

1. Cooling and heating capacity, water flow and pressure drop data are based on high speed running of bare unit (i.e. without return air plenum).

2. Normal Operation:

- Cooling operation: inlet air dry/wet bulb temperature (°C): 27/19.5; water inlet/outlet temperature (°C): 7/12;
- Heating operation: inlet air dry bulb temperature (°C): 21; water inlet temperature (°C): 60; same water flow as cooling operation;

3. EarthWise Operation:

- Cooling operation: inlet air dry/wet bulb temperature (°C): 27/19.5; water inlet/outlet temperature (°C): 5/13;
- Heating operation: inlet air dry bulb temperature (°C): 21; water inlet temperature (°C): 60; same water flow as cooling operation;

4. High Capacity EarthWise operation:

- Cooling operation: inlet air dry/wet bulb temperature (°C): 26.7 °C/19.4 °C; water inlet/outlet temperature (°C): 7.2 °C/15.6 °C;
- Heating operation: inlet air dry bulb temperature (°C): 21; water inlet temperature (°C): 60; same water flow as cooling operation;

5. Same performance for EarthWise application.

6. High capacity earthwise application data is based on medium speed. Other data is based on high speed.

3 Row Unit (2-Pipe, 100Pa Motor)

			11	13	15
Air Flow	High Speed	CMH	1870	2210	2550
	Middle Speed	CMH	1700	1870	2040
	Low Speed	CMH	935	1105	1275
Normal Application	Cooling Capacity	kW	9.78	11.72	13.48
	Heating Capacity	kW	16.41	19.02	21.67
	Heating Capacity (by E-heater) ⁽⁵⁾	kW	3.20	3.60	4.60
	Water Flow	l/s	0.47	0.56	0.64
	Water Pressure Drop	kPa	38	44	53
EarthWise Application	Cooling Capacity	kW	10.42	11.96	13.80
	Heating Capacity	kW	15.81	18.12	20.73
	Water Flow	l/s	0.31	0.36	0.41
	Water Pressure Drop	kPa	40	38	53
High Capacity EarthWise Application	Cooling Capacity	kW	7.03	7.58	9.06
	Heating Capacity	kW	12.30	13.26	15.86
	Water Flow	l/s	0.20	0.22	0.27
	Water Pressure Drop	kPa	38	36	49
Power Consumption (220~240V/50Hz)	High Speed	W	296	303	376
	Medium Speed	W	254	286	312
	Low Speed	W	141	215	227
Power Consumption (220~240V/60Hz)	High Speed	W	319	359	400
	Medium Speed	W	296	318	354
	Low Speed	W	165	243	265
Noise	High Speed	dBA	56.0	57.0	58.0
	Medium Speed	dBA	55.0	55.5	55.5
	Low Speed	dBA	51.5	51.5	51.5
Number of Motors			2	2	2
Working Pressure			1.8MPa		
Coil Type			Copper Tube / Hydrophilic Aluminum Fin		
Fan Type			Forward-Curve Centrifugal Fan		
Motor Type			Single-phase Permanent Split Capacitor		
Water Inlet/Outlet Diameter			Rc 3/4" (Female)		
Drain-pan Type			One-piece Stamping & Electrostatic Coating		
Drain-pan Connection Diameter			R 3/4"(Male)		
Options			Return Air Plenum, Filter, Thermostat, E-heater, Special Drain-pan		

1.Cooling and heating capacity, water flow and pressure drop data are based on high speed running of bare unit (i.e. without return air plenum).

2.Normal Operation:

- Cooling operation: inlet air dry/wet bulb temperature (°C): 27/19.5; water inlet/outlet temperature (°C): 7/12;
- Heating operation: inlet air dry bulb temperature (°C): 21; water inlet temperature (°C): 60; same water flow as cooling operation;

3.EarthWise Operation:

- Cooling operation: inlet air dry/wet bulb temperature (°C): 27/19.5; water inlet/outlet temperature (°C): 5/13;
- Heating operation: inlet air dry bulb temperature (°C): 21; water inlet temperature (°C): 60; same water flow as cooling operation;

4.High Capacity EarthWise operation:

- Cooling operation: inlet air dry/wet bulb temperature (°C): 26.7 °C/19.4 °C; water inlet/outlet temperature (°C): 7.2 °C/15.6 °C;
- Heating operation: inlet air dry bulb temperature (°C): 21; water inlet temperature (°C): 60; same water flow as cooling operation;

5. Same performance for EarthWise application.

6. High capacity earthwise application data is based on medium speed. Other data is based on high speed.

Performance Data

4 Row Unit (2-Pipe, 12/30/50Pa Motor)

		02	03	04	05	06	08	10	12	14	
Air Flow	High Speed	340	510	680	850	1020	1360	1700	2040	2380	
	Middle Speed	280	410	550	690	830	1100	1360	1630	1900	
	Low Speed	180	270	350	440	520	690	860	1020	1190	
Normal Application	Cooling Capacity	kW	2.54	3.66	4.73	5.55	7.01	9.21	11.16	13.07	14.93
	Heating Capacity	kW	4.00	5.69	7.20	8.82	10.73	14.17	17.61	20.16	23.43
	Heating Capacity (by E-heater) ⁽⁵⁾	kW	0.50	1.00	1.40	1.60	1.80	2.80	3.20	3.60	4.60
	Water Flow	l/s	0.12	0.18	0.23	0.27	0.33	0.44	0.53	0.62	0.71
	Water Pressure Drop	kPa	16	20	30	30	34	35	40	40	50
EarthWise Application	Cooling Capacity	kW	2.47	3.56	4.58	5.60	7.24	8.79	10.76	13.05	15.17
	Heating Capacity	kW	3.76	5.40	6.72	8.43	10.37	13.35	16.64	18.87	21.79
	Water Flow	l/s	0.08	0.12	0.14	0.17	0.22	0.29	0.34	0.40	0.42
	Water Pressure Drop	kPa	16	30	28	24	40	40	40	40	50
Power Consumption	12Pa	220 ~ 240V/50Hz	26	39	45	68	96	130	152	189	228
		220 ~ 240V/60Hz	27	43	51	67	85	118	142	178	213
		100 ~ 127V/60Hz	28	40	52	68	79	120	145	179	201
	30Pa	220 ~ 240V/50Hz	41	55	71	87	108	150	174	212	253
		220 ~ 240V/60Hz	36	49	62	87	88	126	163	193	311
		100 ~ 127V/60Hz	33	47	59	81	86	131	166	191	336
	50Pa	220 ~ 240V/50Hz	48	64	84	99	118	164	210	230	290
		220 ~ 240V/60Hz	40	58	77	112	134	189	242	273	333
		100 ~ 127V/60Hz	40	62	75	110	147	195	239	277	374
Noise	12Pa	dBA	34.5	35.5	36.5	40.5	45.0	44	46.5	49.0	51.0
	30Pa	dBA	38.0	40.0	41.5	43.5	46.0	46.5	49.0	51.0	53.0
	50Pa	dBA	41.0	42.5	45.0	47.0	48.0	49.0	51.0	52.0	54.0
Number of Motors			1	1	1	1	1	1	2	2	2
Working Pressure			1.8MPa								
Coil Type			Copper Tube / Hydrophilic Aluminum Fin								
Fan Type			Forward-Curve Centrifugal Fan								
Motor Type			Single-phase Permanent Split Capacitor								
Water Inlet/Outlet Diameter			Rc 3/4" (Female)								
Drain-pan Type			One-piece Stamping & Electrostatic Coating								
Drain-pan Connection Diameter			R 3/4"(Male)								
Options			Return Air Plenum, Filter, Thermostat, E-heater, Special Drain-pan								

1. Cooling and heating capacity, water flow and pressure drop data are based on high speed running of bare unit (i.e. without return air plenum).

2. Normal Operation:

- Cooling operation: inlet air dry/wet bulb temperature (°C): 27/19.5; water inlet/outlet temperature (°C): 7/12;

- Heating operation: inlet air dry bulb temperature (°C): 21; water inlet temperature (°C): 60; same water flow as cooling operation;

3. EarthWise Operation:

- Cooling operation: inlet air dry/wet bulb temperature (°C): 27/19.5; water inlet/outlet temperature (°C): 5/13;

- Heating operation: inlet air dry bulb temperature (°C): 21; water inlet temperature (°C): 60; same water flow as cooling operation;

4. Please refer to model number description for more options.

5. Same performance for EarthWise application.

4 Row Unit (2-Pipe, 100Pa Motor)

			11	13	15
Air Flow	High Speed	CMH	1870	2210	2550
	Middle Speed	CMH	1700	1870	2040
	Low Speed	CMH	935	1105	1275
Normal Application	Cooling Capacity	kW	11.83	13.81	15.58
	Heating Capacity	kW	18.72	21.43	24.51
	Heating Capacity (by E-heater) ⁽⁵⁾	kW	3.20	3.60	4.60
	Water Flow	l/s	0.56	0.66	0.74
	Water Pressure Drop	kPa	45	45	55
EarthWise Application	Cooling Capacity	kW	11.49	13.80	15.80
	Heating Capacity	kW	17.63	20.06	22.78
	Water Flow	l/s	0.34	0.39	0.44
	Water Pressure Drop	kPa	44	41	54
Power Consumption (220~240V/50Hz)	High Speed	W	296	303	376
	Medium Speed	W	254	286	312
	Low Speed	W	141	215	227
Power Consumption (220~240V/60Hz)	High Speed	W	319	359	400
	Medium Speed	W	296	318	354
	Low Speed	W	165	243	265
Noise	High Speed	dBA	56.0	57.0	58.0
	Medium Speed	dBA	55.0	55.5	55.5
	Low Speed	dBA	51.5	51.5	51.5
Number of Motors			2	2	2
Working Pressure			1.8MPa		
Coil Type			Copper Tube / Hydrophilic Aluminum Fin		
Fan Type			Forward-Curve Centrifugal Fan		
Motor Type			Single-phase Permanent Split Capacitor		
Water Inlet/Outlet Diameter			Rc 3/4" (Female)		
Drain-pan Type			One-piece Stamping & Electrostatic Coating		
Drain-pan Connection Diameter			R 3/4"(Male)		
Options			Return Air Plenum, Filter, Thermostat, E-heater, Special Drain-pan		

1.Cooling and heating capacity, water flow and pressure drop data are based on high speed running of bare unit (i.e. without return air plenum).

2.Normal Operation:

- Cooling operation: inlet air dry/wet bulb temperature (°C): 27/19.5; water inlet/outlet temperature (°C): 7/12;
- Heating operation: inlet air dry bulb temperature (°C): 21; water inlet temperature (°C): 60; same water flow as cooling operation;

3.EarthWise Operation:

- Cooling operation: inlet air dry/wet bulb temperature (°C): 27/19.5; water inlet/outlet temperature (°C): 5/13;
- Heating operation: inlet air dry bulb temperature (°C): 21; water inlet temperature (°C): 60; same water flow as cooling operation;

4.Please refer to model number description for more options.

5. Same performance for EarthWise application.

Performance Data

2 Row Unit (2-Pipe, 12/30/50Pa Motor)

		02	03	04	05	06	08	
Air Flow CMH	High Speed	350	520	690	870	1040	1380	
	Middle Speed	280	410	550	700	830	1100	
	Low Speed	180	270	350	450	520	690	
Cooling Capacity	kW	1.90	2.80	3.60	4.50	5.40	7.20	
Heating Capacity	kW	3.15	4.93	6.10	7.41	8.90	12.00	
Heating Capacity (by E-heater) ⁽⁵⁾	kW	0.50	1.00	1.40	1.60	1.80	2.80	
Water Flow	l/s	0.10	0.14	0.17	0.21	0.26	0.34	
Water Pressure Drop	kPa	15	30	25	30	34	36	
Power Consumption	12Pa	220 ~ 240V/50Hz	26	39	45	68	96	130
		220 ~ 240V/60Hz	27	43	51	67	85	118
		100 ~ 127V/60Hz	28	40	52	68	79	120
	30Pa	220 ~ 240V/50Hz	41	55	71	87	108	150
		220 ~ 240V/60Hz	36	49	62	87	88	126
		100 ~ 127V/60Hz	33	47	59	81	86	131
	50Pa	220 ~ 240V/50Hz	48	64	84	99	118	164
		220 ~ 240V/60Hz	40	58	77	112	134	189
		100 ~ 127V/60Hz	40	62	75	110	147	195
	Noise	12Pa	34.5	35.5	36.5	40.5	45.0	44
		30Pa	38.0	40.0	41.5	43.5	46.0	46.5
		50Pa	41.0	42.5	45.0	47.0	48.0	49.0
Number of Motors		1	1	1	1	1	1	
Working Pressure		1.8MPa						
Coil Type		Copper Tube / Hydrophilic Aluminum Fin						
Fan Type		Forward-Curve Centrifugal Fan						
Motor Type		Single-phase Permanent Split Capacitor						
Water Inlet/Outlet Diameter		Rc 3/4" (Female)						
Drain-pan Type		One-piece Stamping & Electrostatic Coating						
Drain-pan Connection Diameter		R 3/4" (Male)						
Options		Return Air Plenum, Filter, Thermostat, E-heater, Special Drain-pan						

1. Cooling and heating capacity, water flow and pressure drop data are based on high speed running of bare unit (i.e. without return air plenum).

2. Normal Operation:

- Cooling operation: inlet air dry/wet bulb temperature (°C): 27/19.5; water inlet/outlet temperature (°C): 7/12;

- Heating operation: inlet air dry bulb temperature (°C): 21; water inlet temperature (°C): 60; same water flow as cooling operation;

3. Please refer to model number description for more options.

4. Same performance for EarthWise application.

2+1 Row Unit (4-Pipe, 12/30/50Pa Motor)

			02	03	04	05	06	08		
Air Flow CMH	High Speed		340	510	680	850	1020	1360		
	Middle Speed		280	410	550	690	830	1100		
	Low Speed		180	270	350	440	520	690		
Cooling Capacity	kW		1.93	2.86	3.81	4.50	5.74	7.22		
Water Flow	kPa		0.10	0.14	0.19	0.22	0.28	0.35		
Water Pressure Drop	kPa		8	16	26	21	25	28		
Heating Capacity (1 Row)	l/s		1.67	2.21	2.50	2.92	3.45	4.11		
Water Flow	kPa		0.07	0.06	0.06	0.06	0.06	0.05		
Water Pressure Drop	kPa		30	30	30	30	40	40		
Power Consumption	12Pa	220 ~ 240V/50Hz		26	39	45	68	96	130	
		220 ~ 240V/60Hz		27	43	51	67	85	118	
		100 ~ 127V/60Hz		28	40	52	68	79	120	
	30Pa	220 ~ 240V/50Hz	W		41	55	71	87	108	150
		220 ~ 240V/60Hz			36	49	62	87	88	126
		100 ~ 127V/60Hz			33	47	58	81	86	131
	50Pa	220 ~ 240V/50Hz		48	64	84	99	118	164	
		220 ~ 240V/60Hz		40	58	77	112	134	189	
		100 ~ 127V/60Hz		40	62	75	110	147	195	
Noise	12Pa	dBA	34.5	35.5	36.5	40.5	45	44		
	30Pa	dBA	38.0	40.0	41.5	43.5	46.0	46.5		
	50Pa	dBA	41.0	42.5	45.0	47.0	48.0	49.0		
Number of Motors		1	1	1	1	1	1	1		
Working Pressure		1.8MPa								
Coil Type		Copper Tube / Hydrophilic Aluminum Fin								
Fan Type		Forward-Curve Centrifugal Fan								
Motor Type		Single-phase Permanent Split Capacitor								
Water Inlet/Outlet Diameter		Rc 3/4" (Female)								
Drain-pan Type		One-piece Stamping & Electrostatic Coating								
Drain-pan Connection Diameter		R 3/4" (Male)								
Options		Return Air Plenum, Filter, Thermostat, E-heater, Special Drain-pan								

1.Cooling and heating capacity, water flow and pressure drop based on high speed running of bare unit (i.e. without return air plenum).

2.Normal Operation:

- Cooling operation: inlet air dry/wet bulb temperature (°C): 27/19.5; water inlet/outlet temperature (°C): 7/12;

- Heating operation (1 row): inlet air dry bulb temperature (°C): 21; water inlet temperature (°C): 60;

3.Please refer to model number description for more options.

Performance Data

3+1 Row Unit (4-Pipe, 12/30/50Pa Motor)

		02	03	04	05	06	08	10	12	14	
Air Flow	High Speed	340	510	680	850	1020	1360	1700	2040	2380	
	Middle Speed	280	410	550	690	830	1100	1360	1630	1900	
	Low Speed	180	270	350	440	520	690	860	1020	1190	
Normal Application	Cooling Capacity	kW	2.17	3.10	4.04	4.96	5.98	7.62	9.02	10.80	12.74
	Water Flow	l/s	0.11	0.15	0.20	0.24	0.30	0.37	0.44	0.52	0.62
	Water Pressure Drop	kPa	25	24	23	30	38	32	33	38	50
EarthWise Application	Cooling Capacity	kW	2.17	2.95	3.97	4.69	5.86	7.61	9.32	10.80	13.02
	Water Flow	l/s	0.07	0.10	0.12	0.15	0.18	0.23	0.28	0.32	0.39
	Water Pressure Drop	kPa	26	18	30	22	38	26	28	29	48
Heating Capacity		kW	2.41	3.16	3.88	4.42	5.20	6.15	7.24	7.67	8.81
Water Flow		l/s	0.14	0.13	0.12	0.11	0.12	0.11	0.11	0.10	0.11
Water Pressure Drop		kPa	30	30	30	30	40	40	40	40	50
Power Consumption	12Pa	220 ~ 240V/50Hz	26	39	45	68	96	130	152	189	228
		220 ~ 240V/60Hz	27	43	51	67	85	118	142	178	213
		100 ~ 127V/60Hz	28	40	52	68	79	120	145	179	201
	30Pa	220 ~ 240V/50Hz	41	55	71	87	108	150	174	212	253
		220 ~ 240V/60Hz	36	49	62	87	88	126	163	193	311
		100 ~ 127V/60Hz	33	47	59	81	86	131	166	191	336
	50Pa	220 ~ 240V/50Hz	48	64	84	99	118	164	210	230	290
		220 ~ 240V/60Hz	40	58	77	112	134	189	242	273	333
		100 ~ 127V/60Hz	40	62	75	110	147	195	239	277	374
		12Pa	34.5	35.5	36.5	40.5	45.0	44	46.5	49.0	51.0
Noise	30Pa	dBA	38.0	40.0	41.5	43.5	46.0	46.5	49.0	51.0	53.0
	50Pa	41.0	42.5	45.0	47.0	48.0	49.0	51.0	52.0	54.0	
Number of Motors			1	1	1	1	1	1	2	2	2
Working Pressure		1.8MPa									
Coil Type		Copper Tube / Hydrophilic Aluminum Fin									
Fan Type		Forward-Curve Centrifugal Fan									
Motor Type		Single-phase Permanent Split Capacitor									
Water Inlet/Outlet Diameter		Rc 3/4" (Female)									
Drain-pan Type		One-piece Stamping & Electrostatic Coating									
Drain-pan Connection Diameter		R 3/4" (Male)									
Options		Return Air Plenum, Filter, Thermostat, E-heater, Special Drain-pan									

1.Cooling and heating capacity, water flow and pressure drop data are based on high speed running of bare unit (i.e. without return air plenum).

2.Normal Operation:

- Cooling operation: inlet air dry/wet bulb temperature (°C): 27/19.5; water inlet/outlet temperature (°C): 7/12;

- Heating operation(1 row): inlet air dry bulb temperature (°C): 21; water inlet temperature (°C): 60;

3.EarthWise Operation:

- Cooling operation: inlet air dry/wet bulb temperature (°C): 27/19.5; water inlet/outlet temperature (°C): 5/13;

- Heating operation(1 row): inlet air dry bulb temperature (°C): 21; water inlet temperature (°C): 60;

4.Please refer to model number description for more options.

3+1 Row Unit (4-Pipe, 100Pa Motor)

			11	13	15
Air Flow	High Speed	CMH	1870	2210	2550
	Middle Speed	CMH	1700	1870	2040
	Low Speed	CMH	935	1105	1275
Normal Application	Cooling Capacity	kW	9.52	11.41	13.27
	Water Flow	l/s	0.45	0.54	0.63
	Water Pressure Drop	kPa	36	42	53
EarthWise Application	Cooling Capacity	kW	9.84	11.37	13.57
	Water Flow	l/s	0.29	0.34	0.40
	Water Pressure Drop	kPa	31	31	51
Heating Capacity		kW	7.44	7.84	8.96
Water Flow		l/s	0.11	0.10	0.11
Water Pressure Drop		kPa	40	40	50
Power Consumption (220~240V/50Hz)	High Speed	W	296	303	376
	Medium Speed	W	254	286	312
	Low Speed	W	141	215	227
Power Consumption (220~240V/60Hz)	High Speed	W	319	359	400
	Medium Speed	W	296	318	354
	Low Speed	W	165	243	265
Noise	High Speed	dBA	56.0	57.0	58.0
	Medium Speed	dBA	55.0	55.5	55.5
	Low Speed	dBA	51.5	51.5	51.5
Number of Motors			2	2	2
Working Pressure			1.8MPa		
Coil Type			Copper Tube / Hydrophilic Aluminum Fin		
Fan Type			Forward-Curve Centrifugal Fan		
Motor Type			Single-phase Permanent Split Capacitor		
Water Inlet/Outlet Diameter			Rc 3/4" (Female)		
Drain-pan Type			One-piece Stamping & Electrostatic Coating		
Drain-pan Connection Diameter			R 3/4"(Male)		
Options			Return Air Plenum, Filter, Thermostat, E-heater, Special Drain-pan		

1.Cooling and heating capacity, water flow and pressure drop data are based on high speed running of bare unit (i.e. without return air plenum).

2.Normal Operation:

- Cooling operation: inlet air dry/wet bulb temperature (°C): 27/19.5; water inlet/outlet temperature (°C): 7/12;
- Heating operation(1 row): inlet air dry bulb temperature (°C): 21; water inlet temperature (°C): 60;

3.EarthWise Operation:

- Cooling operation: inlet air dry/wet bulb temperature (°C): 27/19.5; water inlet/outlet temperature (°C): 5/13;
- Heating operation(1 row): inlet air dry bulb temperature (°C): 21; water inlet temperature (°C): 60;

4.Please refer to model number description for more options.

Airflow Curve(12/30/50Pa Motor)

220 ~ 240V-50Hz

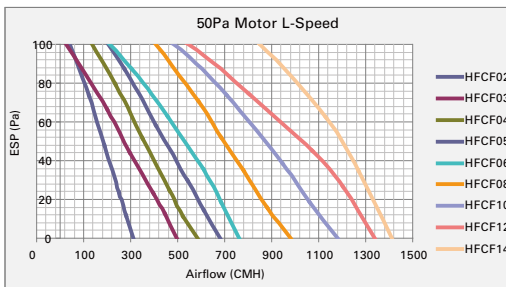
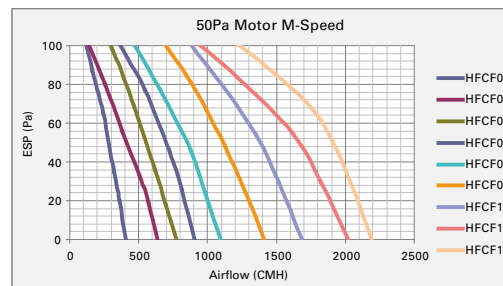
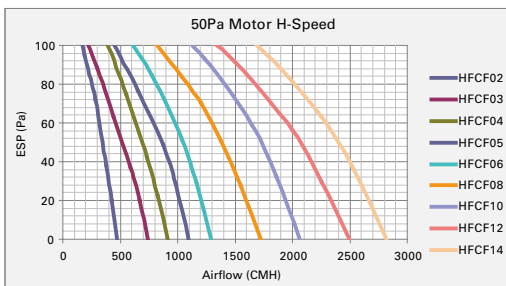
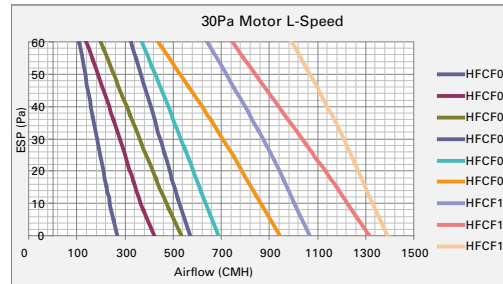
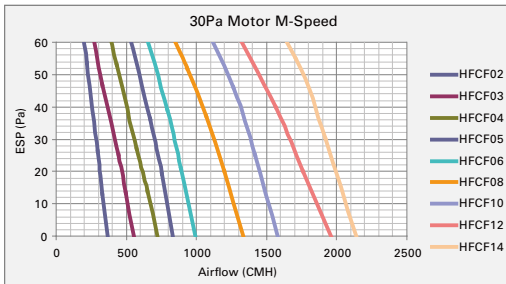
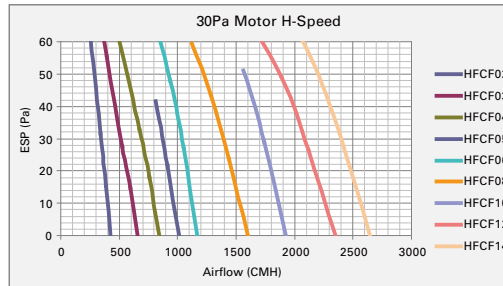
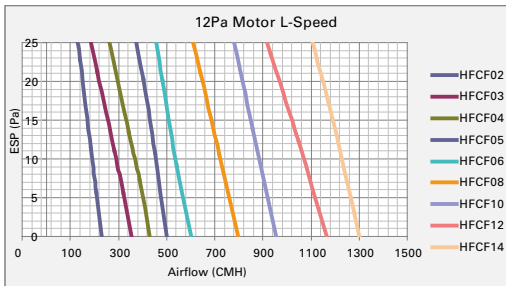
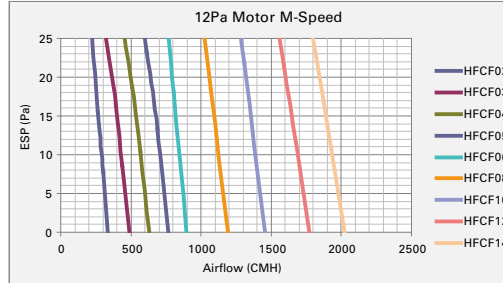
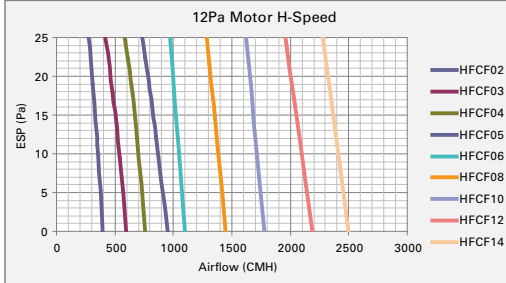

220 ~ 240V-60Hz

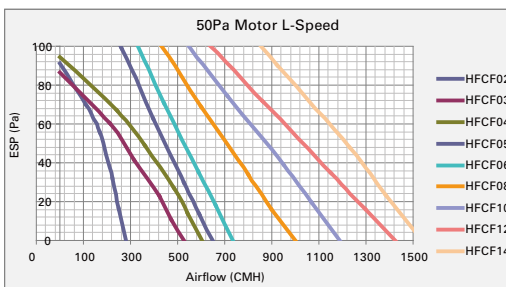
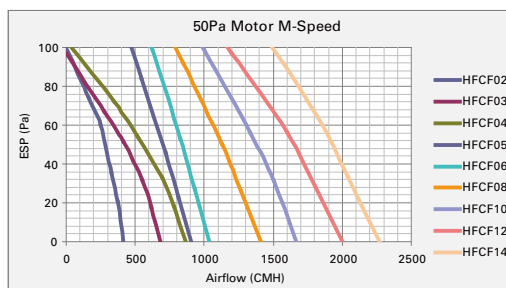
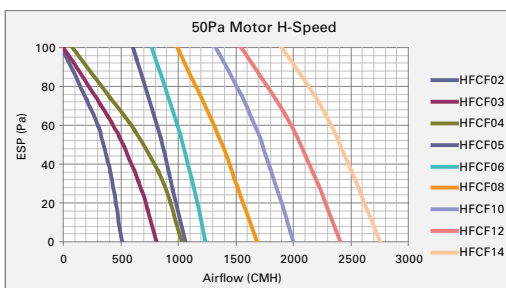
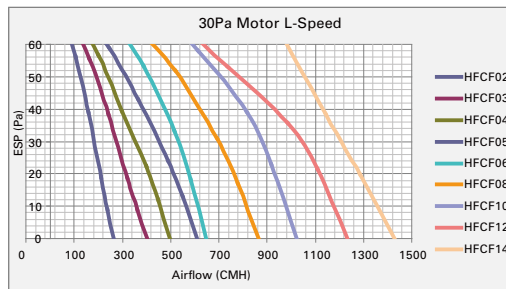
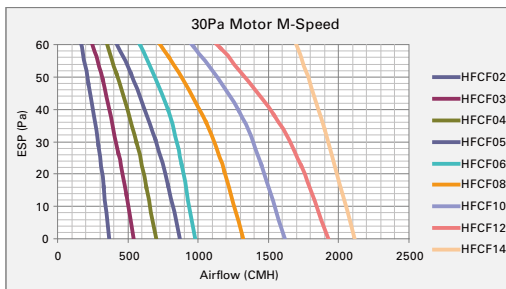
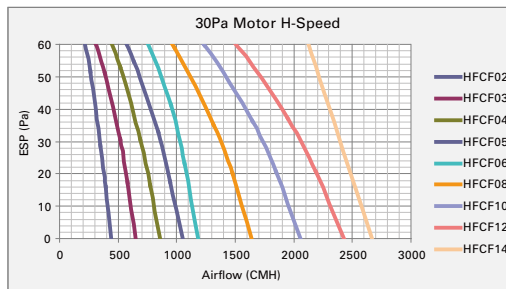
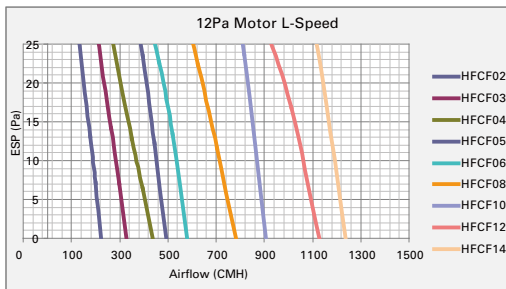
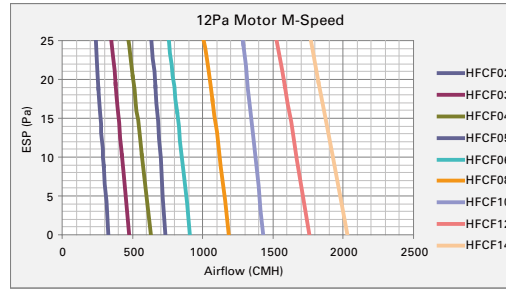
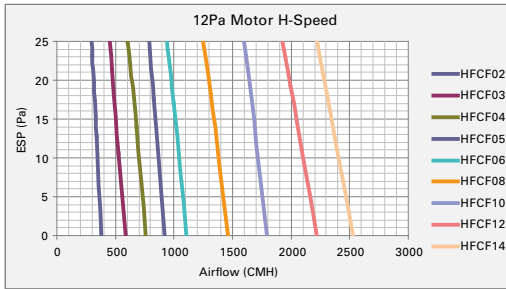

Airflow Curve(12/30/50Pa Motor)

110 ~ 127V-60Hz

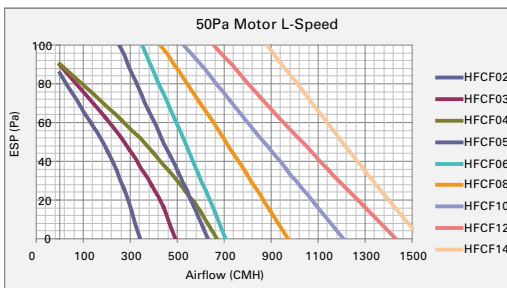
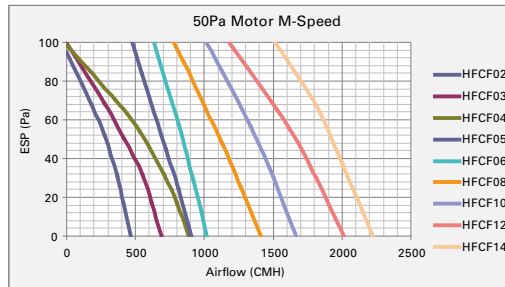
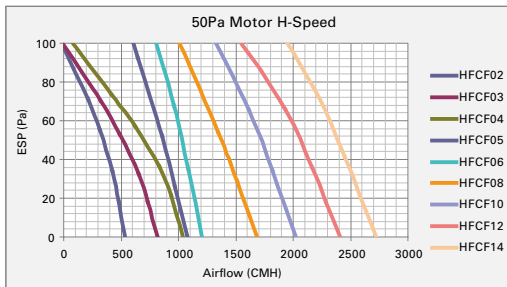
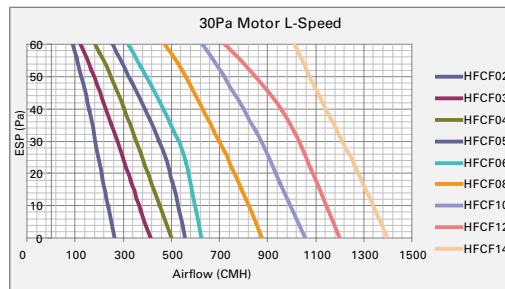
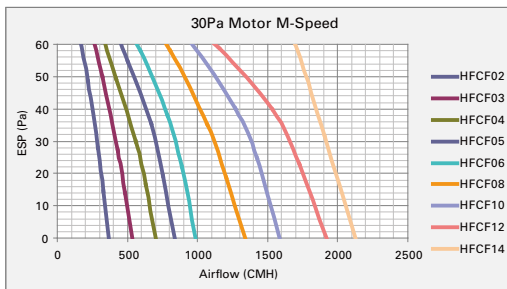
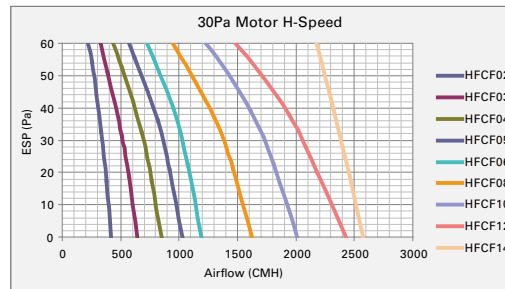
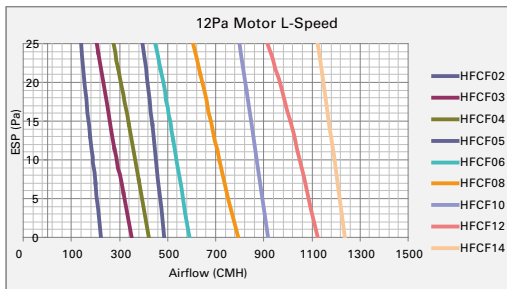
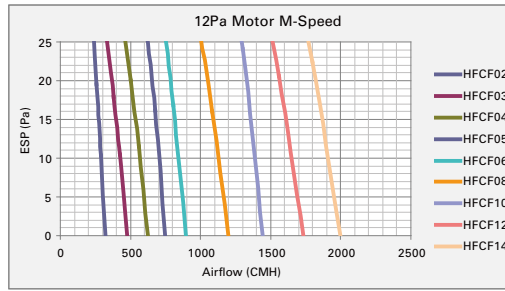
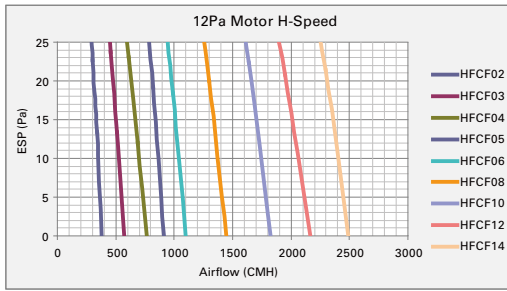

Airflow Curve (100Pa Motor)

220 ~ 240V-50Hz

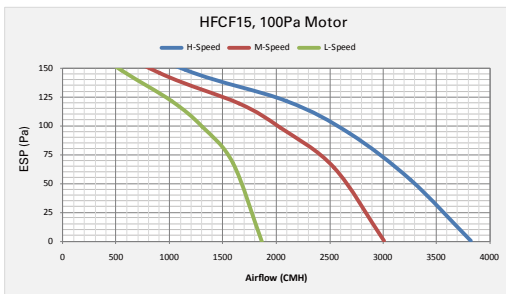
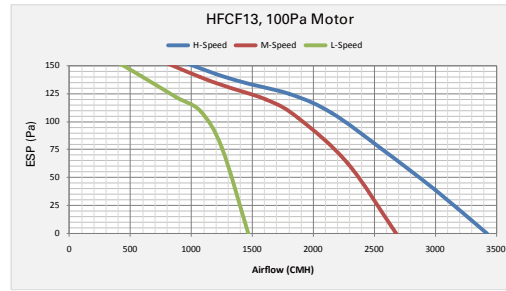
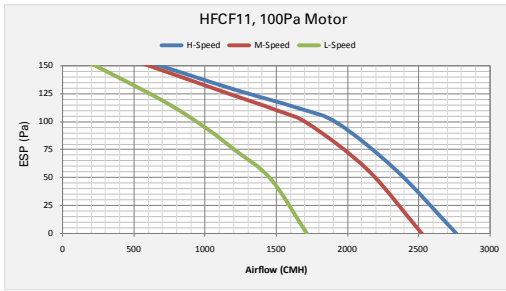

220 ~ 240V-60Hz

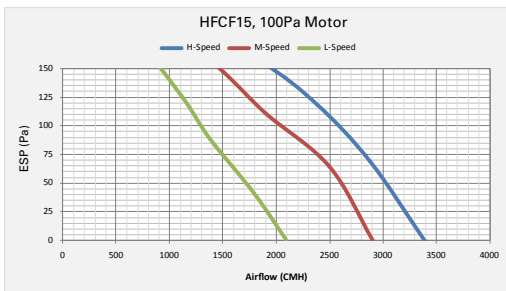
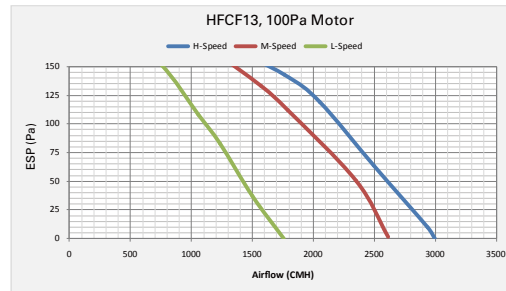
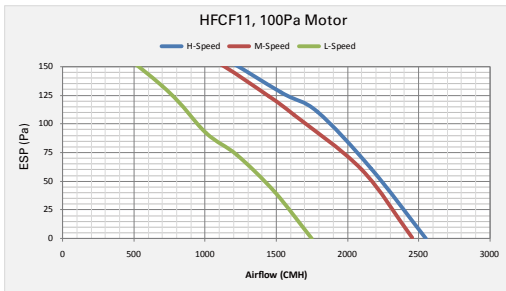

Note: Please use Trane TOPSS program or contact Trane sales to get selectable range for various configurations.

Wiring Diagram

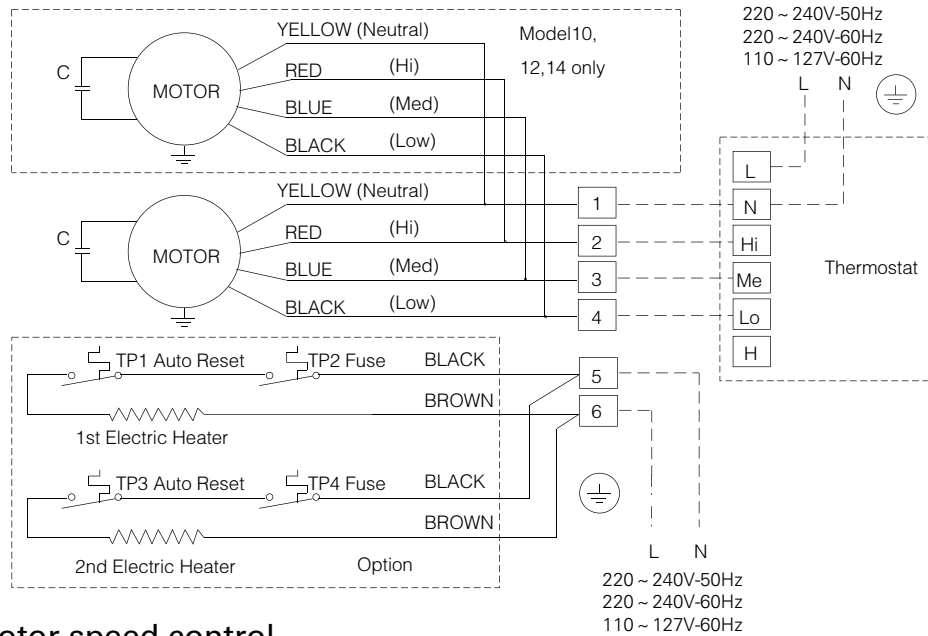

Motor speed control

Yellow and Red Wires = High Speed
Yellow and Blue Wires = Medium Speed
Yellow and Black Wires = Low Speed

Trane can provide terminal boxes with relay inside to support e-heater application and you can freely choose according to your needs.

Warning:

1. Units with different sizes or motor types are not allowed to be wired in parallel to be controlled by one thermostat.
2. Max. 2 units with same sizes and motor types may be wired in parallel to be controlled by one thermostat, provided that the thermostat capacity is large enough to control two units.
3. Only qualified personnel should install and service the equipment.
4. Cut off power before any service or maintenance starts.

Dimensions and Weights

2-pipe (without return plenum)

Unit:mm

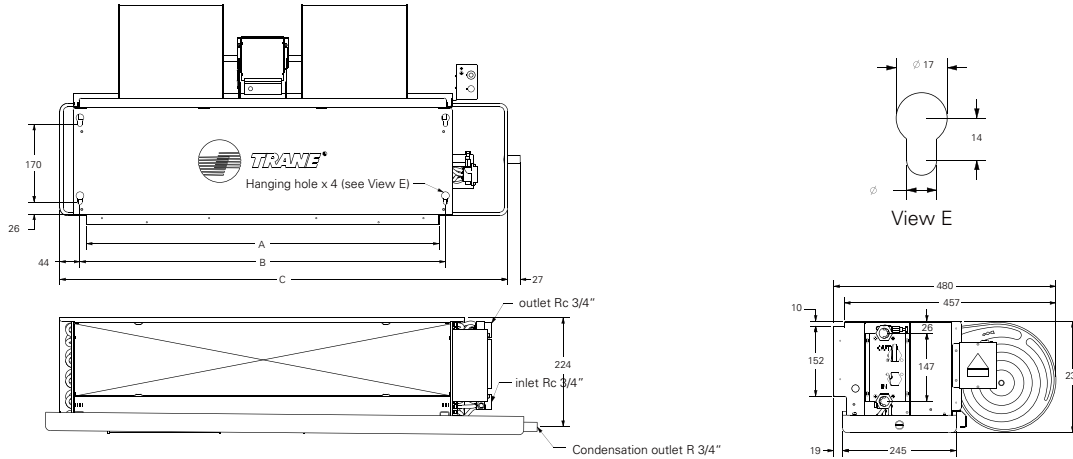

2-pipe (with return plenum)

Unit:mm

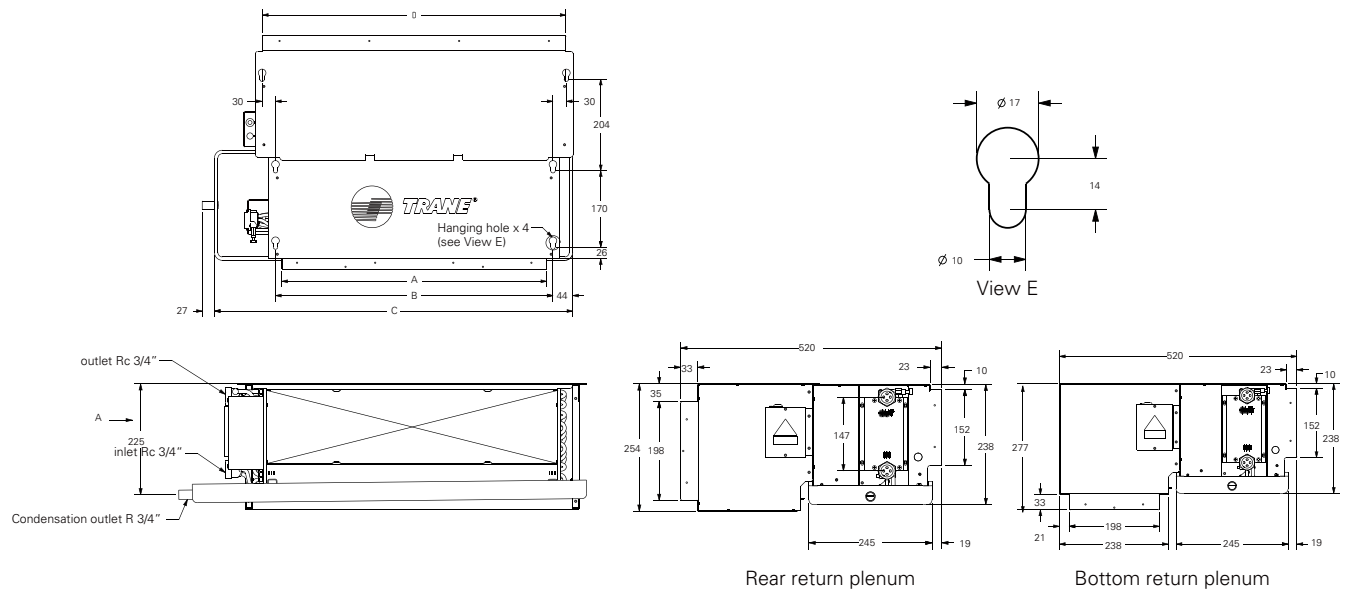

Dimension (mm)	Weight (kg)																								
	Without return plenum								With return plenum																
	12Pa				30Pa				50Pa				12Pa				30Pa				50Pa				
A	B	C*	D	2 Row	3 Row	4 Row	2 Row	3 Row	4 Row	2 Row	3 Row	4 Row	2 Row	3 Row	4 Row	2 Row	3 Row	4 Row	2 Row	3 Row	4 Row	2 Row	3 Row	4 Row	
HFCF02	440	468	648	526	10	11	11	10.5	11	11	10.5	11	11.5	13.5	14	14	13.5	14	14	13.5	14	14	13.5	14	14.5
HFCF03	590	618	798	676	13	14	14	13	14	14	13.5	14	14	17	17.5	17.5	17	17.5	17.5	17	17.5	17	17.5	17	17.5
HFCF04	690	718	898	776	15	15	16	15	15.5	16	15	15.5	16	19	19.5	20.5	19	19.5	20	19	19.5	20	19	19.5	20
HFCF05	770	798	978	856	15.5	16	17	16	17	17	16	17	17.5	19.5	20	21	20	20.5	20.5	20	21	21	20.5	20.5	21.5
HFCF06	970	998	1183	1056	18.5	19	21	19	20	21	19	20	21	23.5	24	25	23.5	24	25	24	24.5	24	24.5	25	25.5
HFCF08	1210	1238	1423	1296	26	27	28	26	27	28	26.5	27	28	32	33	34	32	33	34	32	33	34	32	33	34
HFCF10	1330	1358	1543	1416	-	31	32	-	31	32	-	31	32	-	37.5	38.5	-	37.5	38.5	-	37.5	38.5	-	37.5	38.5
HFCF12	1570	1598	1783	1656	-	34	35	-	34	35	-	34	35	-	41.5	42.5	-	42	43	-	42	43	-	42	43
HFCF14	1750	1778	1963	1836	-	36	37.5	-	36.5	37.5	-	36.5	38	-	44.5	45.5	-	45	46	-	45	46	-	45	46.5
					100Pa								100Pa												
					3 Row				4 Row				3 Row				4 Row								
HFCF11	1330	1358	1543	1416	33				34				39.5				40.5								
HFCF13	1570	1598	1783	1656	36				36.5				44				45								
HFCF15	1750	1778	1963	1836	37.5				39				46				47.5								

Note:
 C dimension is standard drain pan length.
 Add 200 to C dimension to get +200mm extended drain pan length.
 Add 310 to C dimension to get +310mm extended drain pan length.

Dimensions and Weights

4-pipe

Unit:mm

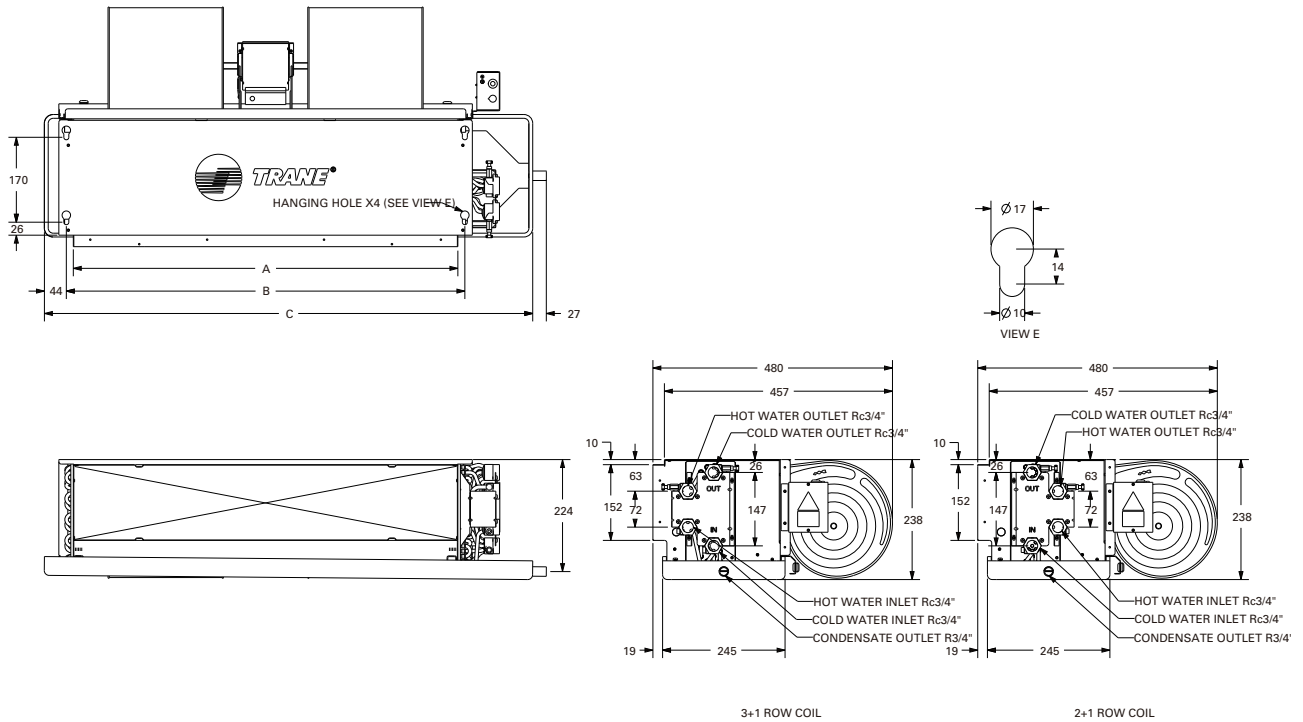

Dimension (mm)	Weight (kg)															
	Without return plenum						With return plenum									
	12Pa		30Pa		50Pa		12Pa		30Pa		50Pa					
A	B	C*	D	2+1 Row	3+1 Row	2+1 Row	3+1 Row	2+1 Row	3+1 Row	2+1 Row	3+1 Row	2+1 Row	3+1 Row	2+1 Row	3+1 Row	
HFCF02	440	468	648	526	11	11.5	11	11.5	11	12	14	14.5	14	14.5	14	15
HFCF03	590	618	798	676	14	14	14	14.5	14	14.5	17	17	17	17.5	17	17.5
HFCF04	690	718	898	776	15	16	16	16	16	16	18	19	19	19	19	19
HFCF05	770	798	978	856	16	17	17	18	17	18	19	20	20	21	20	21
HFCF06	970	998	1183	1056	19.5	20	20	21	20	21	22.5	23	23	24	23	24
HFCF08	1210	1238	1423	1296	27	28	27	28	28	28	30	31	30	31	31	31
HFCF10	1330	1358	1543	1416	-	32	-	32	-	32	-	35	-	35	-	35
HFCF12	1570	1598	1783	1656	-	35	-	35.5	-	35.5	-	38	-	38.5	-	38.5
HFCF14	1750	1778	1963	1836	-	38	-	38	-	38	-	41	-	41	-	41
					100Pa						100Pa					
					3+1 Row						3+1 Row					
HFCF11	1330	1358	1543	1416	34						37					
HFCF13	1570	1598	1783	1656	37.5						40.5					
HFCF15	1750	1778	1963	1836	39						42					

Note:
 C dimension is standard drain pan length.
 Add 200 to C dimension to get +200mm extended drain pan length.
 Add 310 to C dimension to get +310mm extended drain pan length.

Options Valve Package

Specifications

Optional offer to provide factory-assembled valve package, including 2- or 3-way ON/OFF valve with electric actuator. Trane offers suitable drain-pan to best accommodate different package and avoid any condensation risk.

Easy Installation

- Industrial standard thread joint for pipe connection.
- Terminal box for electrical wiring connection.

Low Installation Cost

- Eliminate field installed for controls valve packaged and its accessories.
- Quick installation time and save field workmanship cost.

Compact Design

- Extended drain pan up to substantial length for piping connection.

2-way/3-way Valve



Power Consumption	Nominal Pressure	Close-off Pressure	IP Grade	Power Supply	Kv's	Valve on-off Speed	Pipe connection
6.5W	2.1MPa	344KPa	IP51	220-240V 100-127V	2.2 2.6	4-5s(Spring) 13-18s (motor)	DN20 Female Thread

3-way Valve

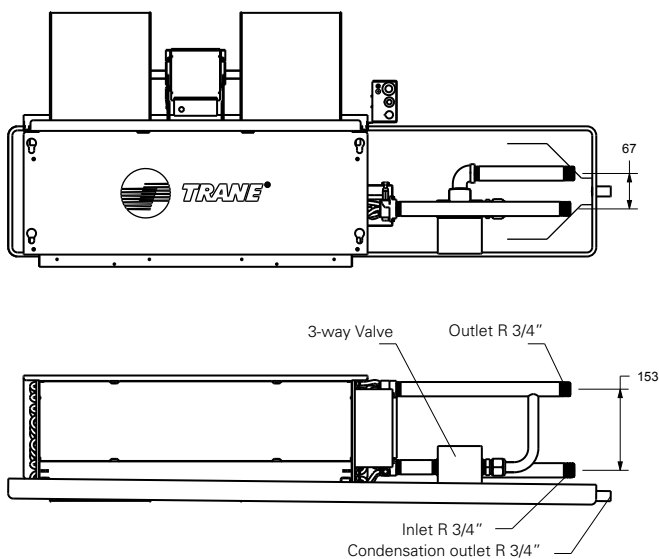

2-way Valve

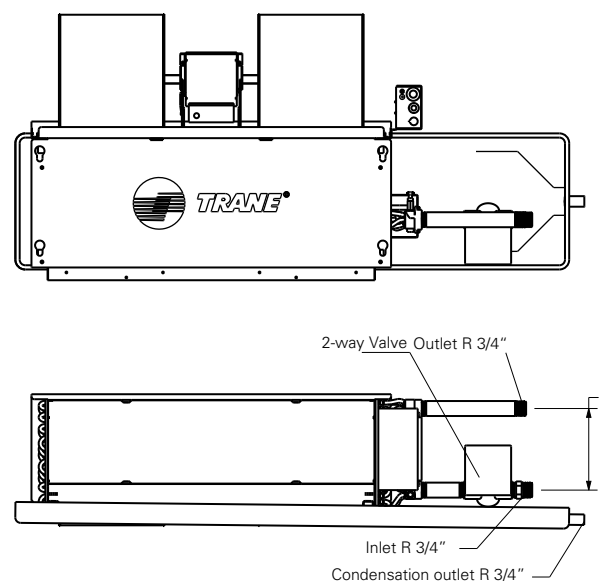

Note: Please select extended Drain-pan (200mm) for 2-way Valve and 310mm for 3-way valve.



Ingersoll Rand (NYSE:IR) advances the quality of life by creating comfortable, sustainable and efficient environments. Our people and our family of brands—including Club Car®, Ingersoll Rand®, Thermo King® and Trane®—work together to enhance the quality and comfort of air in homes and buildings; transport and protect food and perishables; and increase industrial productivity and efficiency. We are a global business committed to a world of sustainable progress and enduring results. For more information, visit www.ingersollrand.com.

Ingersoll Rand has a policy of continuous product and product data improvements and reserves the right to change design and specifications without notice.