



Product Catalog

Water Source Heat Pump Air to Water/Packaged Unit

GEHC 012~060

Cooling: 4.1~16.7kW

Heating: 5.1~20.9kW

50Hz



Features and Benefits

Overview

Imagine a comfort system with high efficiency, low operating noise and smart controls while Trane recognized those with customers concern. Therefore, Trane water source heat pump functions to be a comfort solution as with an effective system.

The entire range of GEHC (Packaged Water Source Heat Pump) has been designed with outstanding quality in mind:

- Ease of maintenance
- High efficiency
- Low operating noise

The use of coaxial coil achieves maximum heat transfer and minimum fouling as well as scaling.

The full range GEHC is applicable to small or medium sized buildings, schools, industries, health care centers and commercial applications.

Flexible Application

The GEHC has flexible configuration in system design. Providing front and side supply air configurations are significantly convenient for local installation. The hanging brackets reside in each corner of unit. This particular design eliminates extra clearances required to the product besides of quick installation.

Accurate Control

Advanced microprocessor functions unit control with visibility of LCD controller or in peers configuration for system expansion.

Noise Control

State-of-Art acoustical design makes GEHC in minimum noise during operation.

Low Investment

With water source heat pump system, mechanical room could be saved for units allocation, hence less piping design is required. Therefore, initial cost of investment can be reduced significantly.

Easy Retrofit and Individual Operation

Water source heat pump system offers flexibility for speculative buildings. Extended units can be installed and connected to an existing system for additional spaces. This also gives space for meter devices to individuals who pay electricity bills independently. Furthermore, one unit's failure will not affect the operation of the whole system.



Model Number Descriptions

<u>G</u>	<u>E</u>	<u>H</u>	<u>C</u>	<u>0</u>	<u>1</u>	<u>2</u>	<u>6</u>	<u>1</u>	<u>M</u>	<u>O</u>	<u>1</u>	<u>1</u>	<u>L</u>	<u>R</u>	<u>E</u>
1	2	3	4	5	6	7	8	9	10	11	12	13	14	15	16
Digits 1-2		Product Type GE = Packaged Unit													
Digit 3			H = Horizontal Configuration												
Digits 4				Development Sequence C											
Digits 5-7					Unit Size 012 024 030 036 048 060										
Digit 8						Voltage/Hertz/Phase 6=220~240V/50Hz/1Ph (012-030) 9=380~415V/50Hz/3Ph (036-060)									
Digit 9							Thermostat 1 = With LCD Thermostat (Applicable Single or Modular Configuration) 2 = Without LCD Thermostat (For Modular Configuration Only)								
Digit 10								Controller M = Microprocessor Control							
Digit 11									Refrigeration Cycle C = Cooling O = Heat Pump						
Digit 12										System Application 1 = Water Loop (Cooling Tower System) 2 = Ground Water (Opened System) 3 = Ground Loop (Closed System)					
Digit 13											Blower Configuration 1 = Normal Static Pressure				
Digit 14												Supply Air Arrangement L = Left Side T = Front			
Digit 15													Return Air Arrangement N = w/o Filter R = w/6 mm Nylon filter T = w/12 mm Aluminum filter		
Digit 16															Region E = Export

System Overview

Typical Diagram of Water Source Heat Pump System for Commercial Application

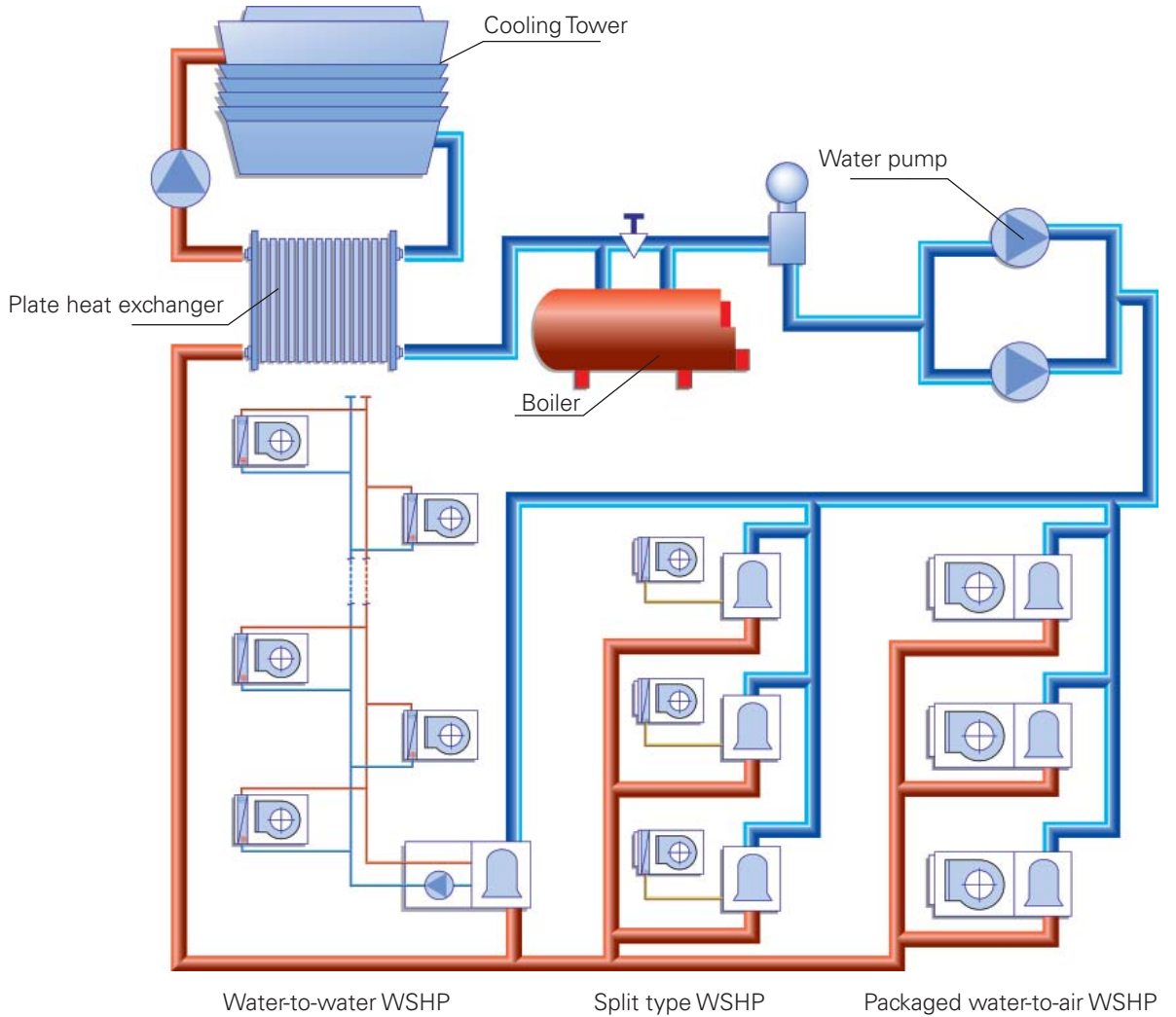

Note: Above diagram was sketched for reference only. Please consult designers for professional advice.

General Data

Model		GEHC012	GEHC024	GEHC030	GEHC036	GEHC048	GEHC060	
Cooling Capacity	Kcal/Hr	3539	6113	8145	9307	12941	14396	
	Btu/h	13974	24140	32164	36754	51102	56848	
	kW	4.11	7.10	9.46	10.81	15.03	16.72	
Heating Capacity	Kcal/Hr	4426	8042	10013	10866	14654	17995	
	Btu/h	17476	31756	39542	42908	57868	71060	
	kW	5.14	9.34	11.63	12.62	17.02	20.90	
Power Supply	V/Ph/Hz	220 ~ 240/1/50			380 ~ 415/3/50			
Nominal Airflow	m ³ /h	930	1600	2100	1845	3200		
Compressor	Type	Rotary			Scroll			
	QTY	1						
Input Power	Cooling	kW	1.06	1.94	2.37	2.80	3.66	4.57
	Heating	kW	1.01	1.93	2.83	2.94	3.67	4.99
Running Current	A	5.72	9.70	12.87	6.58	9.57	10.59	
EER	W/W	3.88	3.66	3.99	3.86	4.11	3.66	
Condenser	Type	Coaxial Coil						
	Water Flow Rate	m ³ /h	0.9	1.62	2.05	2.30	2.45	3.78
	Water Pressure Drop	kPa	39	46	48	48	55	55
Refrigerant	Type	R410 A						
Refrigerant Charge	kg	0.74	1.07	1.25	1.37	1.73	1.93	
Dimensions (WxDxH)	mm	800x470x400	980x520x430		1080x630x520	1300x720x520		
Return Air Collar Dimensions(LxW)	mm	352x306	512x334		532x426	752x426		
Supply Air Collar Dimensions(LxW)	mm	298x258	300x300		356x357	356x357		
Filter Dimensions(LxW)	mm	348x302	508x330		528x422	748x422		
Operating Weight	kg	68	72	83	130	142	148	
External Static Pressure With Nylon Filter	Pa	20	30					
Water Connections	Inch	1/2" FPT	3/4" MPT					
Drain Connection	mm	16(OD)						

Notes:

- 1.The unit has been tested in cooling tower condition of GB/T 19409-2003 requirement.
- 2.Cooling conditions:Indoor entering air dry/wet bulb temperatures are 27°C/19°C; entering and leaving water temperatures are 30°C/35°C.
- 3.Heating conditions:Indoor entering air dry/wet bulb temperatures are 20°C/15°C; entering water temperatures are 20°C.



Performance Data - Variable Conditions

Model	Nominal Airflow	Nominal Water Flow Rate	Cooling(EDB 27°C/WB19°C)			Heating(EDB 20°C)		
	CMH	CMH	EWT °C	Cooling Capacity (kW)	Input Power (kW)	EWT °C	Cooling Capacity (kW)	Input Power (kW)
GEHC012	930	0.90	20	4.46	0.87	13	4.75	1.01
			24	4.32	0.94	15	5.01	1.01
			30	4.11	1.06	20	5.14	1.01
			35	3.91	1.17	24	5.72	1.00
			40	3.72	1.17	30	6.00	0.98
GEHC024	1600	1.62	20	7.71	1.58	13	8.63	1.94
			24	7.47	1.72	15	9.10	1.93
			30	7.10	1.94	20	9.34	1.93
			35	6.76	2.14	24	10.39	1.92
			40	6.42	2.14	30	10.90	1.88
GEHC030	2100	2.05	20	10.28	1.94	13	10.74	2.39
			24	9.95	2.10	15	11.33	2.38
			30	9.46	2.37	20	11.63	2.38
			35	9.00	2.61	24	12.93	2.36
			40	8.56	2.62	30	13.58	2.32
GEHC036	1845	2.45	20	11.74	2.29	13	11.66	2.95
			24	11.37	2.48	15	12.29	2.95
			30	10.81	2.80	20	12.62	2.94
			35	10.29	3.09	24	14.03	2.92
			40	9.78	3.09	30	14.73	2.86
GEHC048	3200	3.46	20	16.33	2.99	13	15.72	3.68
			24	15.81	3.24	15	16.57	3.68
			30	15.03	3.66	20	17.02	3.67
			35	14.31	4.04	24	18.92	3.64
			40	13.60	4.04	30	19.87	3.57
GEHC060	3200	3.78	20	18.16	3.73	13	19.31	5.01
			24	17.59	4.05	15	20.35	5.00
			30	16.72	4.57	20	20.90	4.99
			35	15.91	5.04	24	23.24	4.95
			40	15.12	5.04	30	24.40	4.86

Correction Factors and Electrical Data

Correction Factor for Airflow

Airflow	Cooling			Heating	
	Total Load (kW)	Sensible Load (kW)	Input Power (kW)	Total Load	Output Power (kW)
80%	0.97	0.89	0.96	0.97	1.03
85%	0.98	0.92	0.97	0.98	1.02
90%	0.99	0.95	0.98	0.99	1.02
95%	0.99	0.97	0.99	0.99	1.01
100%	1	1	1	1	1
110%	1.01	1.05	1.02	1.01	0.98
115%	1.02	1.08	1.03	1.02	0.98
120%	1.03	1.1	1.04	1.03	0.97

Correction Factor for Entering Air Temperature

Cooling								Heating		
Entering WB Temperature (°C)	Total Load (kW)	Input Power (kW)	Sensible Capacity Factor Corresponding Entering DB Temperature (°C)					Entering DB Temperature °C	Total Load (kW)	Input Power (kW)
			19	21	24	27	32			
10	0.76	0.92	/	/	/	/	/	12	1.05	0.93
15	0.85	0.95	0.78	0.86	/	/	/	15	1.03	0.95
17	0.94	0.97	0.5	0.71	0.92	1.13	/	17	1.02	0.98
19	1	1	0.37	0.57	0.79	1	1.21	20	1	1
23	1.12	1.03	/	/	0.52	0.73	0.94	23	0.98	1.02
24	1.18	1.04	/	/	/	0.5	0.72	27	0.96	1.06

Electrical Data

Model	Voltage/Hz	Compressor		Compressor QTY	Fan (FLA)	Fan QTY	Maximum circuit current (MCA)	Recommended fuse specification (REC)	Maximum fuse specification (MFS)	Minimum cross section of copper wire mm ²
		RLA	LRA							
GEHC012	220~240V/50Hz	5.6	32	1	0.7	1	6.3	8.19	10.08	2.5
GEHC024	220~240V/50Hz	10.3	60	1	1.5	1	11.8	15.34	18.88	2.5
GEHC030	220~240V/50Hz	12.7	68	1	1.7	1	14.4	18.72	23.04	4
GEHC036	380~415V/50Hz	8	43	1	1.7	1	9.7	12.61	15.52	2.5
GEHC048	380~415V/50Hz	10.3	51.5	1	3.3	1	13.6	17.68	21.76	4
GEHC060	380~415V/50Hz	13	74	1	3.3	1	16.3	21.19	26.08	4

Dimensions

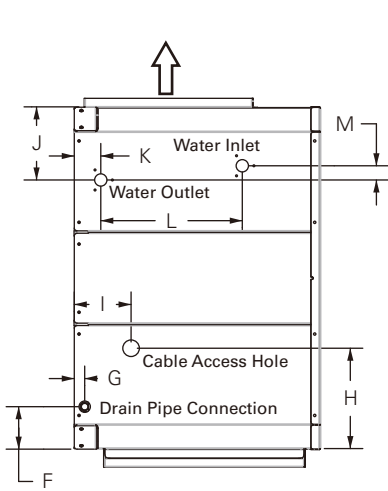

View A

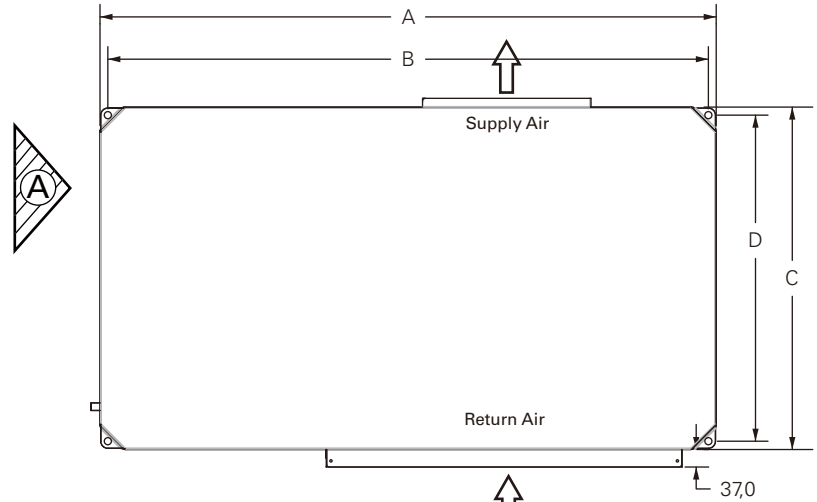

Top View

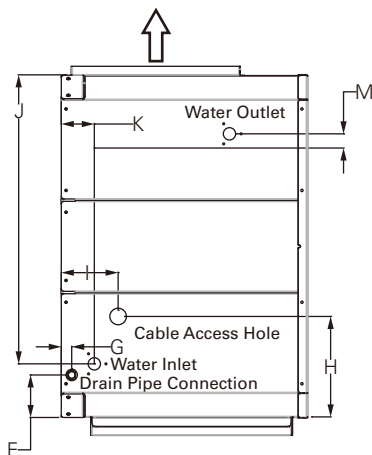

View A
(For GEHC012 only)

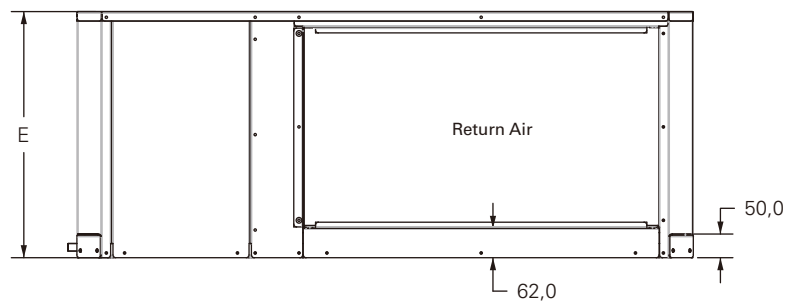

Side View

Unit:mm

Model	A	B	C	D	E	F	G	H	I	J	K	L	M
GEHC012	800	769	470	436	400	89	22	95	225	401	100	71	330
GEHC024	900	952	520	492	430	89	22	112	280	128	79	196	29
GEHC030/036	1080	1049	630	498	520	89	22	167	120	131	51	229	33
GEHC048/060	1300	1269	720	688	520	89	22	212	120	153	56	229	30

Installations

Clearance

Access to the unit for service purposes should be provided at installation. All 1/2 through 5 ton configurations require an 18" (457mm) surround clearance from other mechanical and electrical equipment (where shown) to enable panel removal from the unit for service/maintenance ability. Some local codes may require a greater service clearance than listed here. Check all code requirements prior to unit installations.

Water Pipes Connection

1. Installation of water pipings should be designed in the way that winding upward and downward placement are reduced as much as possible.
2. Flexible hose is recommended to be installed between unit and system piping. This will reduce vibration and prevent pipeline leakage effectively.
3. It is recommended to install shut-off device on the supply and return of the system, the unit may be isolated during service or maintenance situation.
4. Keep sufficient water pressure in the system to ensure water flow rate.
5. A water strainer must be used on an open loop system to keep debris from entering the unit heat exchanger and to ensure a clean system.
6. The water pipe must be insulated to prevent generation of condensate water.

Drainage Method

1. Install proper trapping to the equipment.
2. When designing the condensate trap for the water-source system, it's important to consider the unit's draw-thru design requiring negative pressure trapping.
3. It is imperative to maintain water in the trap and not allow the trap to dry out during the hot season. Keeping trap primed always that will ensure flowing water properly.
4. The unit should contain a dual 1/4 to 12-inch pitch toward the drain connection. This will insure proper drainage of the unit.

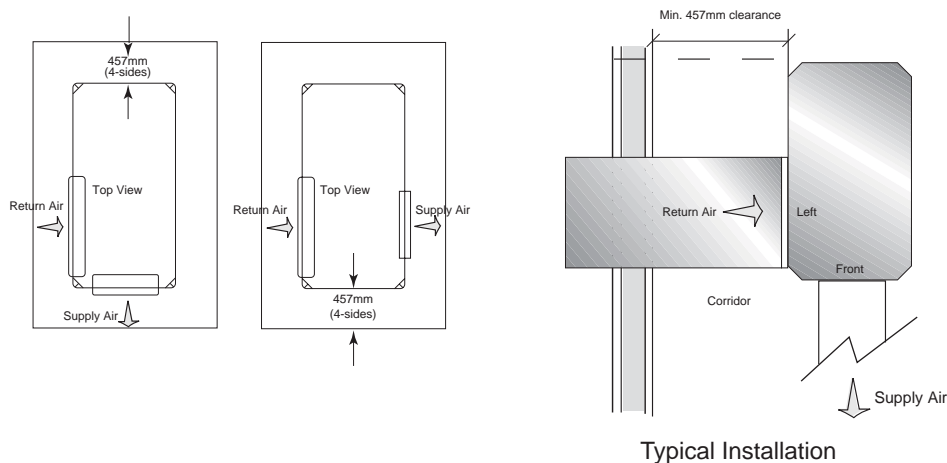

Duct Design for Noise Control

Noise Control

A water source heat pump is typically located in, or very close to the occupied space. Because the unit includes both compressor and fan as those with sound source components, proper acoustical material shall also be considered during an architectural design. Most of the problems associated with equipment homing noise could be avoided by selecting and locating units properly. Additionally, acoustic modeling can be used to predict space acoustical performance and determine cost effective design to meet a specific noise requirement. There are, however, some general recommendations as a guideline of noise control for designing water source heat pump systems.

Typical Sound Paths

There are primarily three different types of sound paths:

1. Airborne: This is a path where sound travels with, or against, the direction of airflow. In a HVAC system, sound travels along with this type of path throughout ductworks or air plenum.
2. Breakout: This typical path is typically associated with sound breaking out and transmitting through duct walls to space.
3. Transmission: This is a path where sound travels throughout the ceiling, floor and walls.

Ductwork Installation

For water source heat pump that uses ductwork design, in whatever of supply air and return air distributions are critical against noise control in an occupied space. Typical installation with an example below helps to keep noise control effectively.

- At least two perpendicular elbows along with supply air duct
- Lining the first 5 ft. (1.5m) at inner surface of supply air duct and length away of the fan discharge.
- The first tee is placed at least two duct diameters downstream from the fan discharge.
- Design supply air grilles in multiple locations.
- Design with low air velocity inside air duct.
- Isolate air ducts, water pipes and electrical connection out of unit vibration.

Unit Installation

1. The best method of obtaining acceptable sound level is to place units at proper locations, for instance, inside a false ceiling or in an unoccupied area.
2. The unit must be suspended with isolators and maintained about 2.5 meters between units in order to avoid transmitting vibration noise.
3. Avoid installing units adjacent to hard surfaces without sound wave reflection.
4. For serving sensitive area, one inch thickness of insulation is recommended adhesive to the bottom surface of unit. This field supplied insulation should be sized in twice of the unit footprint for absorbing noise effectively while unit in operation.

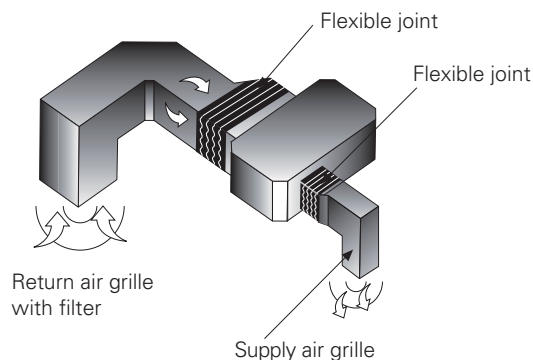

Wiring Diagram

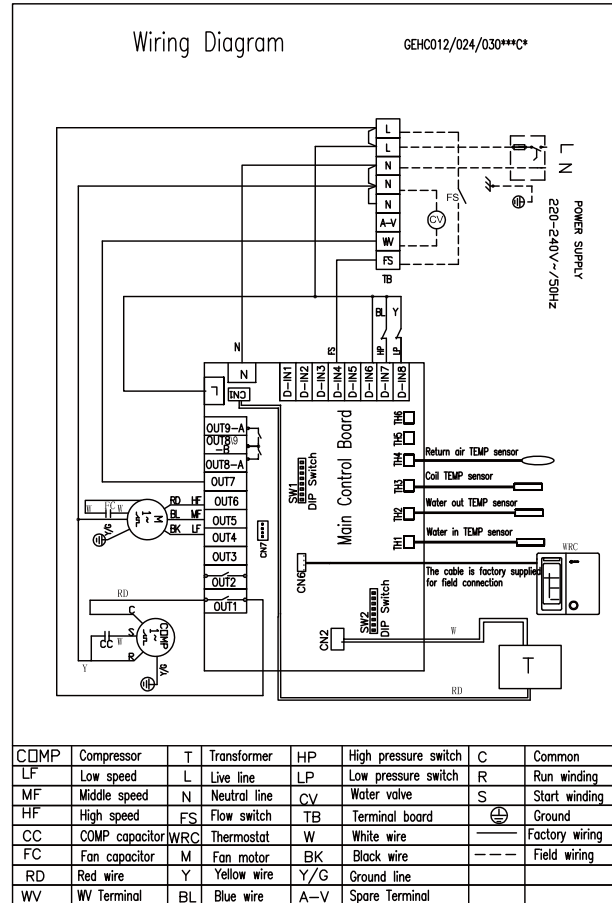
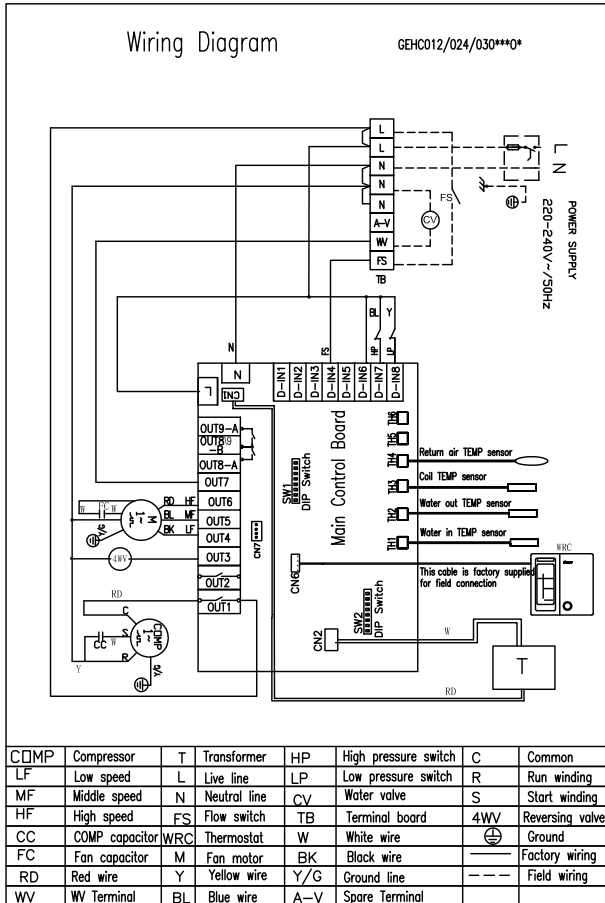

Notes:

1. Loss power will cause a failure signal and manual reset is necessary.
2. Control valve (CV) and flow switch (FS) shall be purchased by others for field installation.
3. FS is a mandatory device, while CV is an option.

Wiring Diagram

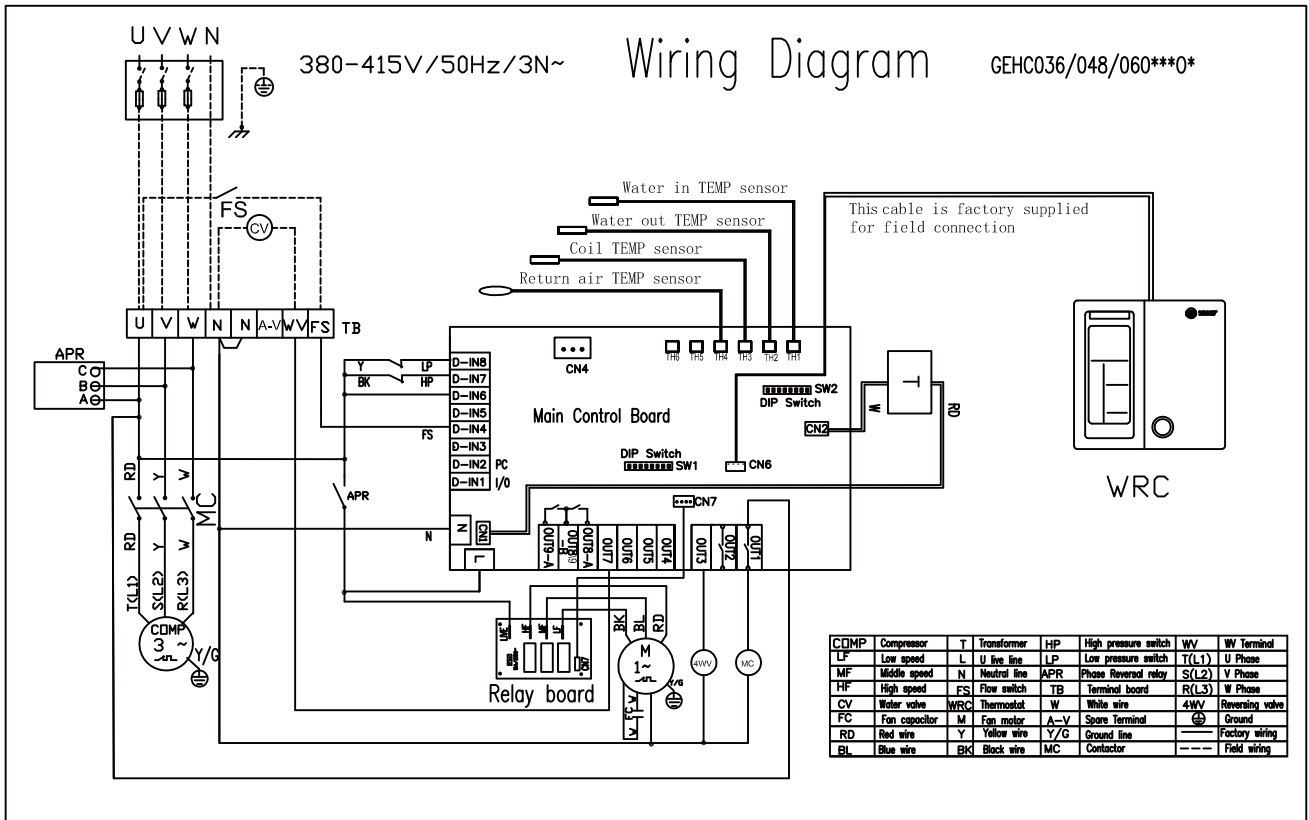
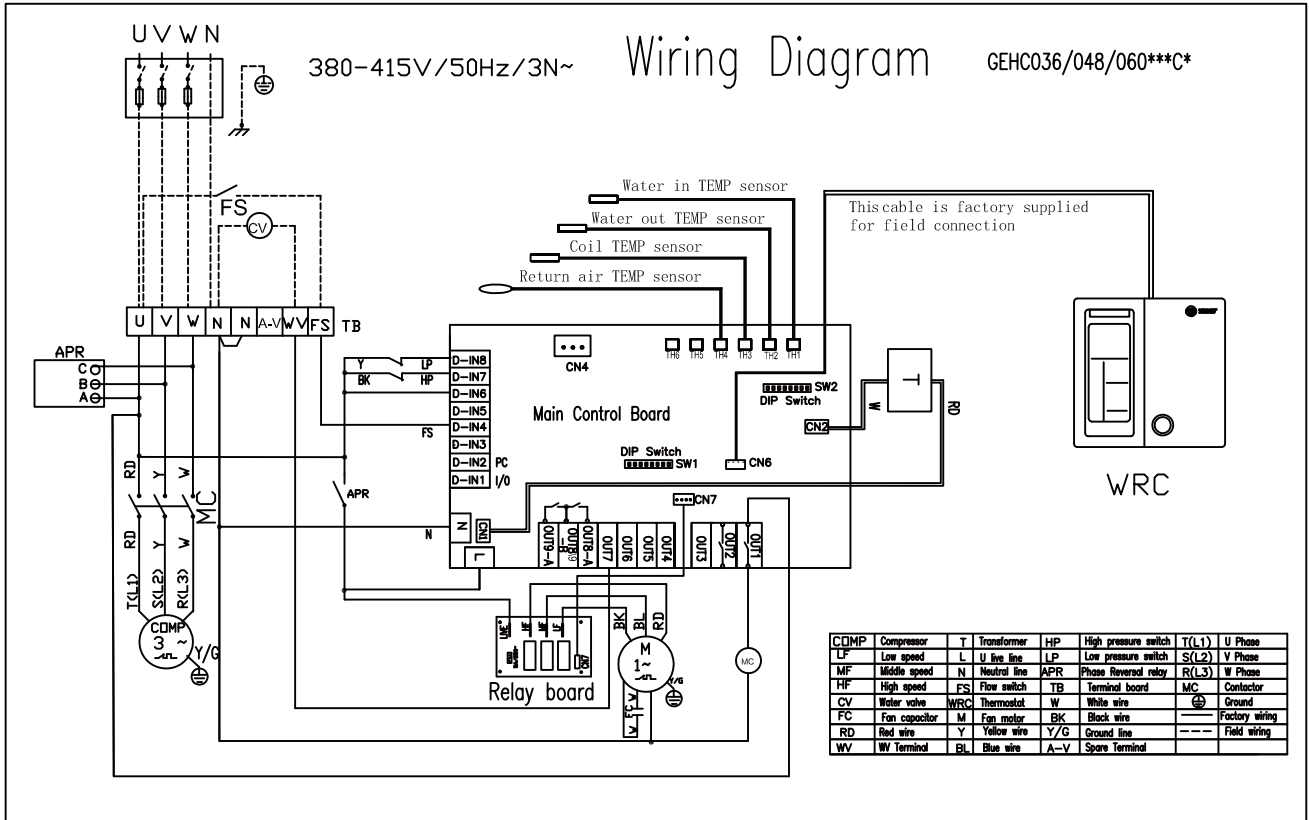



Trane optimizes the performance of homes and buildings around the world. A business of Ingersoll Rand, the leader in creating and sustaining safe, comfortable and energy efficient environments, Trane offers a broad portfolio of advanced controls and HVAC systems, comprehensive building services, and parts. For more information, visit www.Trane.com.

Trane has a policy of continuous product and product data improvement and reserves the right to change design and specifications without notice.